

Tie rod cylinder ISO 15552, Series ITS

- Ø 160-320 mm
- Ports G 3/4 G 1
- double-acting
- Cushioning Pneumatically adjustable
- Piston rod External thread
- ATEX optional

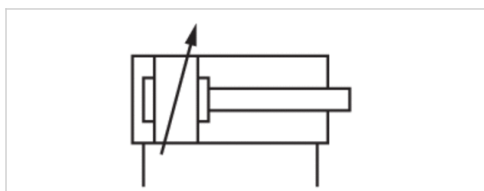

Standards	ISO 15552
Certificates	ATEX optional
Compressed air connection	Internal thread
Working pressure min./max.	2 ... 10 bar
Ambient temperature min./max.	-20 ... 80 °C
Medium temperature min./max.	-20 ... 80 °C
Medium	Compressed air
Max. particle size	50 µm
Oil content of compressed air	0 ... 5 mg/m ³
Pressure for determining piston forces	6.3 bar



Technical data

Piston Ø Piston rod thread Ports Piston rod Ø	160 mm M36x2 G 3/4 40 mm	200 mm M36x2 G 3/4 40 mm	250 mm M42x2 G 1 50 mm	320 mm M48x2 G 1 63 mm
Stroke 25	R480627283	R480627355	R480627427	R480627439
50	R480627284	R480627356	R480627428	R480627440
80	R480627285	R480627357	R480627429	R480627441
100	R480627286	R480627358	R480627430	R480627442
125	R480627287	R480627359	R480627431	R480627443
160	R480627288	R480627360	R480627432	R480627444
200	R480627289	R480627361	R480627433	R480627445
250	R480627290	R480627362	R480627434	R480627446
320	R480627291	R480627363	R480627435	R480627447
400	R480627292	R480627364	R480627436	R480627448
500	R480627293	R480627365	R480627437	R480627449

Technical data

Piston Ø	160 mm	200 mm	250 mm	320 mm
Retracting piston force	11875 N	19000 N	29688 N	48704 N
Extracting piston force	12667 N	19792 N	30925 N	50668 N
Cushioning length	50 mm	50 mm	64 mm	55 mm
Cushioning energy	160 J	170 J	180 J	190 J
Weight 0 mm stroke	12,5 kg	15,67 kg	25,87 kg	46,89 kg
Weight +10 mm stroke	0,21 kg	0,21 kg	0,38 kg	0,61 kg
Stroke max.	2700 mm	2700 mm	2500 mm	2500 mm

Technical information

The pressure dew point must be at least 15 °C under ambient and medium temperature and may not exceed 3 °C .

The oil content of compressed air must remain constant during the life cycle.

Use only the approved oils from AVENTICS. Further information can be found in the "Technical information" document (available in the MediaCentre).

ATEX-certified cylinders with identification II 2G c IIB T4 / II 2D c IP65 T135°C X can be generated in the Internet configurator.

Technical information

Material	
Cylinder tube	Aluminum, anodized
Piston rod	Stainless steel
Front cover	Aluminum
Seal	Acrylonitrile butadiene rubber
Nut for piston rod	Steel, galvanized
Scraper	Acrylonitrile butadiene rubber
Tie-rods	Stainless steel

Dimensions

Dimensions

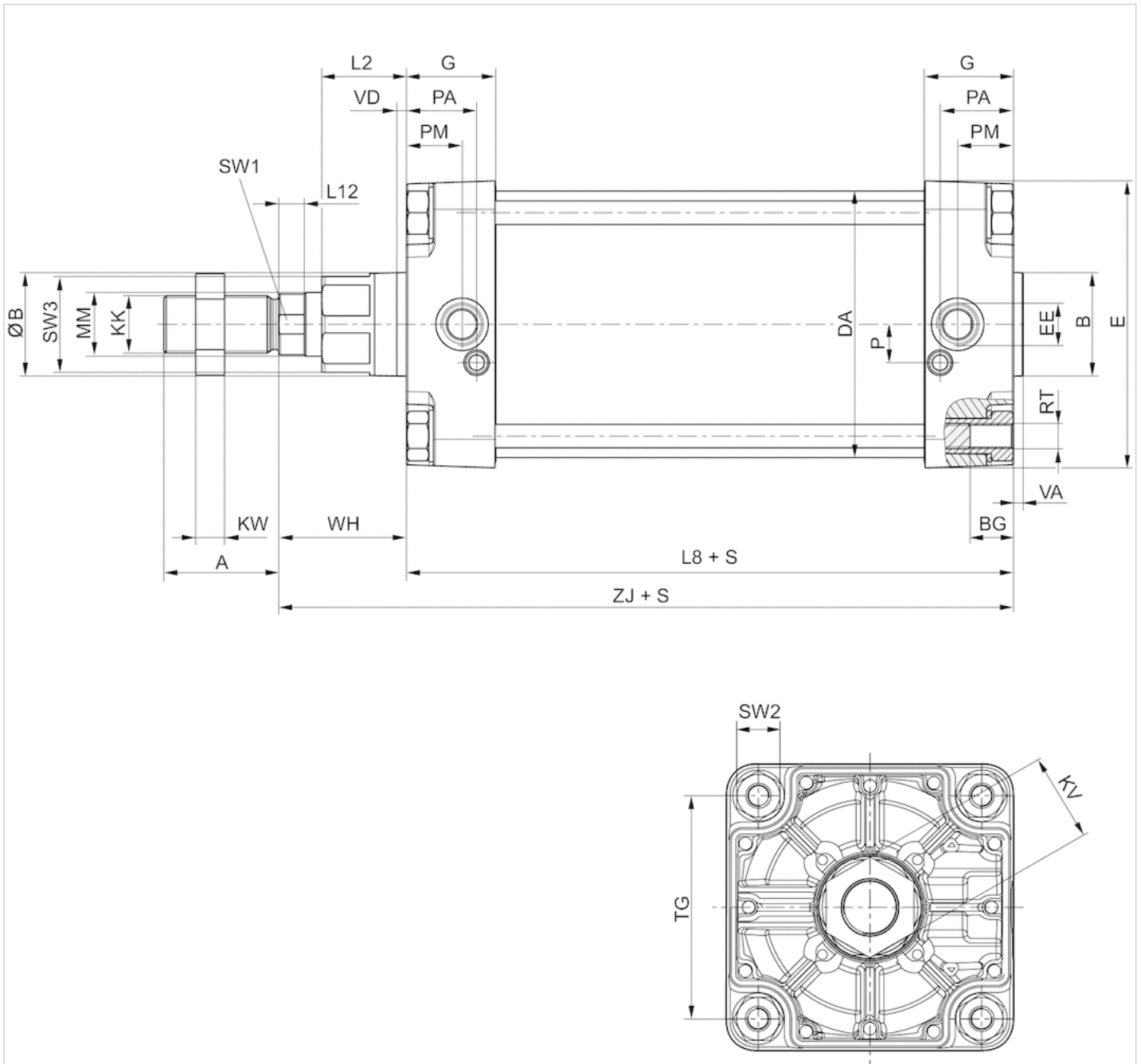

S = stroke

Dimensions

Piston Ø	A	B	ØB	BG	DA	E	EE	G	KK	KV	KW	L2	L8	L12	MM	P	PA	PM	RT
160 mm	72	65	65	24	167	180	G 3/4	56	M36x2	55	18	53	180	16	40	24	45	35	M16
200 mm	72	75	75	24	210	220	G 3/4	54	M36x2	55	18	56	180	16	40	22.5	42	30	M16
250 mm	84	90	90	25	262	280	G 1	59.5	M42x2	65	21	67	200	20	50	29	46	32.8	M20
320 mm	96	110	110	28	336	350	G 1	61.5	M48x2	75	24	76	220	23.25	63	30	48	37	M24

Piston Ø	SW1	SW2	SW3	TG	VA	VD	WH	ZJ
160 mm	36	27	60	140	6	6	80	260
200 mm	36	27	60	175	6	6	95	275
250 mm	46	41	80	220	10	31	105	305.3
320 mm	55	50	95	270	10	34	120	340.5

Diagrams

Cushioning diagram

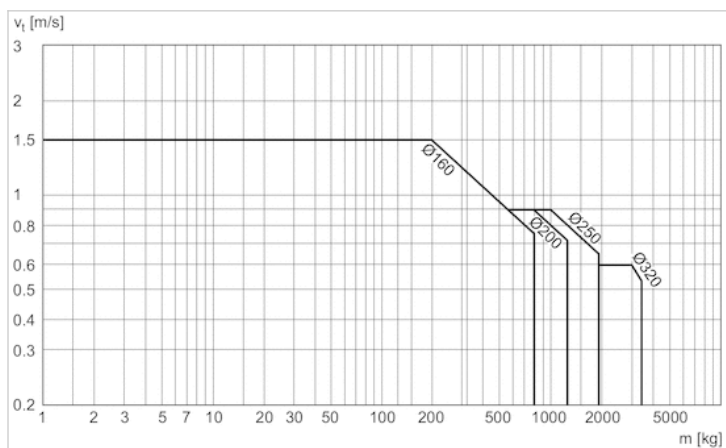

v = Piston velocity [m/s] m = Cushionable mass [kg]

Accessories overview

Overview drawing

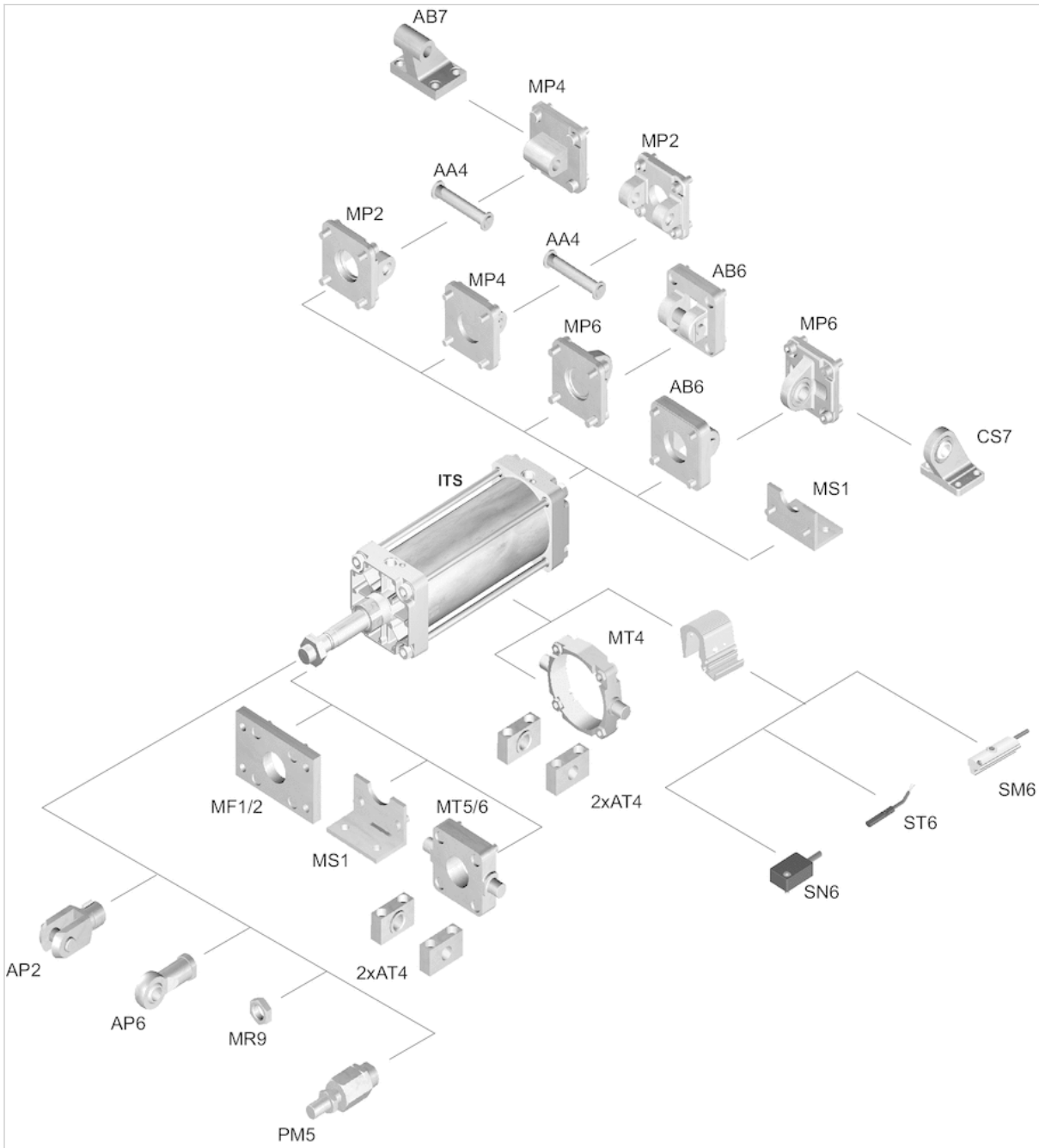

NOTE: This overview drawing is only for orientation to indicate where the various accessory parts can be fastened to the cylinder. The illustration has been simplified for this purpose. It is thus not possible to derive the dimensions from this overview.